



HEBEI DINGSHENG MACHINERY MANUFACTURE CO.,LTD

## Hydraulic Pressure Packaging Machine

Our semi-automatic hydraulic baling machine, automatic pusher hydraulic packing machine is mainly used in various plastic factories, waste paper factories, recycling company etc, suitable for film, forage, straw, cotton, rags, waste paper, etc. Plastic packaging and recycling is an ideal equipment for improving labor efficiency, reducing labor intensity, saving manpower and reducing transportation costs. The nominal pressure is 20 tons, 30 tons, 40 tons, 40 tons, 60 tons, 160 tons, and other specifications, and can be designed and customized according to the requirements of users.





# HEBEI DINGSHENG MACHINERY MANUFACTURE CO.,LTD

## Specification

Model	HPM-10	HPM-20	HPM-30	HPM-60	HPM-80
Box size (mm)	800*400*700	800*400*700	1000*600*800	1200*800*900	1200*800*900
Pressure weight (kg)	40-60	60-90	130-160	200-300	300-400
Motor power (kw)	5.5	7.5	10	15	18.5
Hydro-cylinder size (mm)	1140	1250	1140*2	1600*2	1800*2
Total dimension (mm)	1500*800*2800	1500*800*2800	1700*1050*2800	1800*1300*3200	1800*1300*3200
Machine weight (kg)	900	980	1500	2000	2200
Delivery time (days)	20	20	20	20	20

## Four main working system

### 1>Host Frame System

High quality thick steel plate, with Gas shielded welding sturdy frame, advanced mechanical design makes the equipment durable.

### 2>Conveying System

High quality thick beam frame, high-strength steel conveyor belt style.

### 3>Hydraulic System

Hydraulic pumps, solenoid valves and hydraulic cylinder seals and other key parts use imported components, making high packing pressure, low-speed block, durable and small noise.

### 4>Electronic Control System

Adopt siemens motor, original PLC programmable controller. Other buttons of paper compactor machine, sensors, infrared shooting, remote control systems and other key parts adopt imported components, realizing simple operation and easy maintenance.

## Character

1. The speed of packing is high, it takes only 1 minute for each bundle to be finished.
2. the imported relay is used to control the circuit, which effectively prolongs the service life of the equipment;
3. the rigid plate of 5 mm thick is used.
4. This hydraulic baling machine has the advantages of moderate operating height, simple and convenient operation, and more ease of operation. Suitable for packing lighter items.
5. with improved design and careful manufacture of professional R & D centers, the use of hydraulic baling machines has been continuously expanded, straw, plastics, pulp, powder, Paper scraps can be packed.
6. Hydraulic packaging machine is a mechanical structure, some of the key parts of the use of domestic famous parts



HEBEI DINGSHENG MACHINERY MANUFACTURE CO.,LTD



### Machine Inner Structure

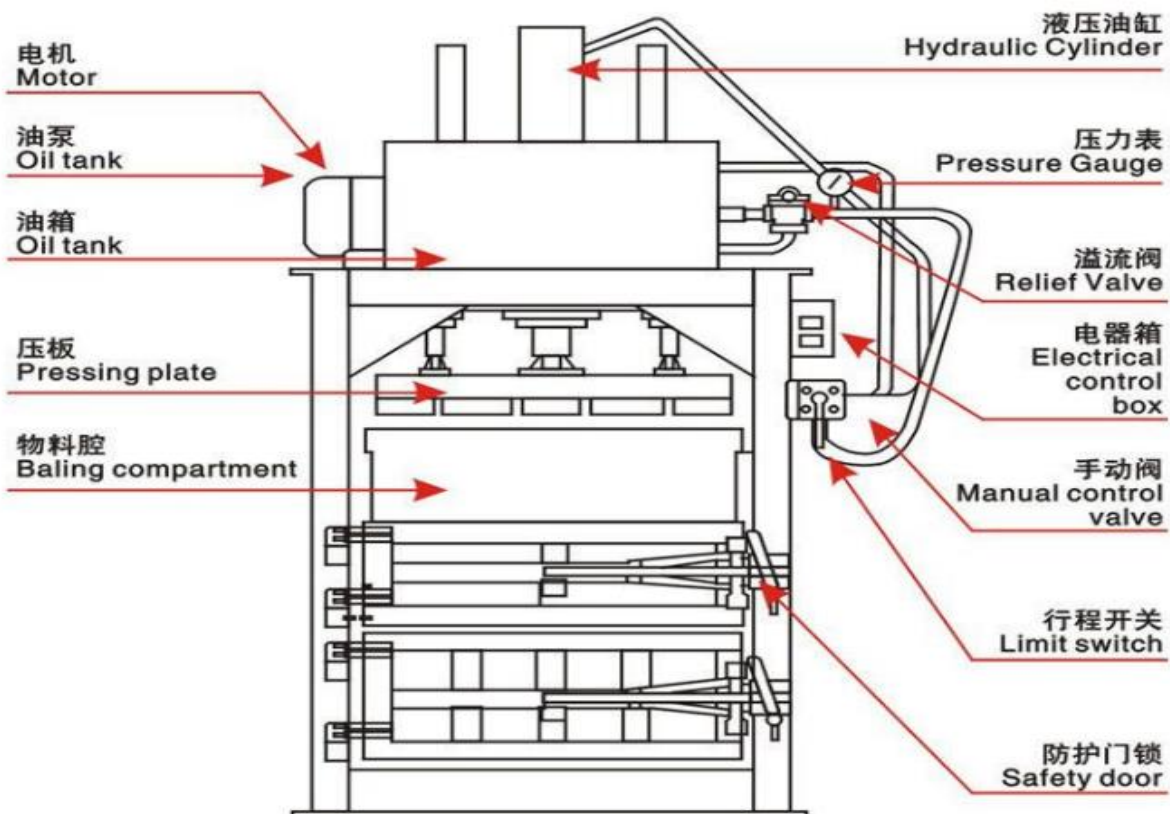



# HEBEI DINGSHENG MACHINERY MANUFACTURE CO.,LTD



1 Hydraulic plate



2 Door lock



3 Safety door



4 Motor



5 Hydraulic cylinder



6 Push out device

## Special Design





# HEBEI DINGSHENG MACHINERY MANUFACTURE CO.,LTD

Application for waste paper,plastic,cloth,metal...





HEBEI DINGSHENG MACHINERY MANUFACTURE CO.,LTD

**Packed by Wooden Case**



**Other Terms:**

We promise that our machine has two year's guarantee and delivery within 20 days after receiving the 30% TT.